

* innen bündig zum Verzinken
inside flush for galvanizing

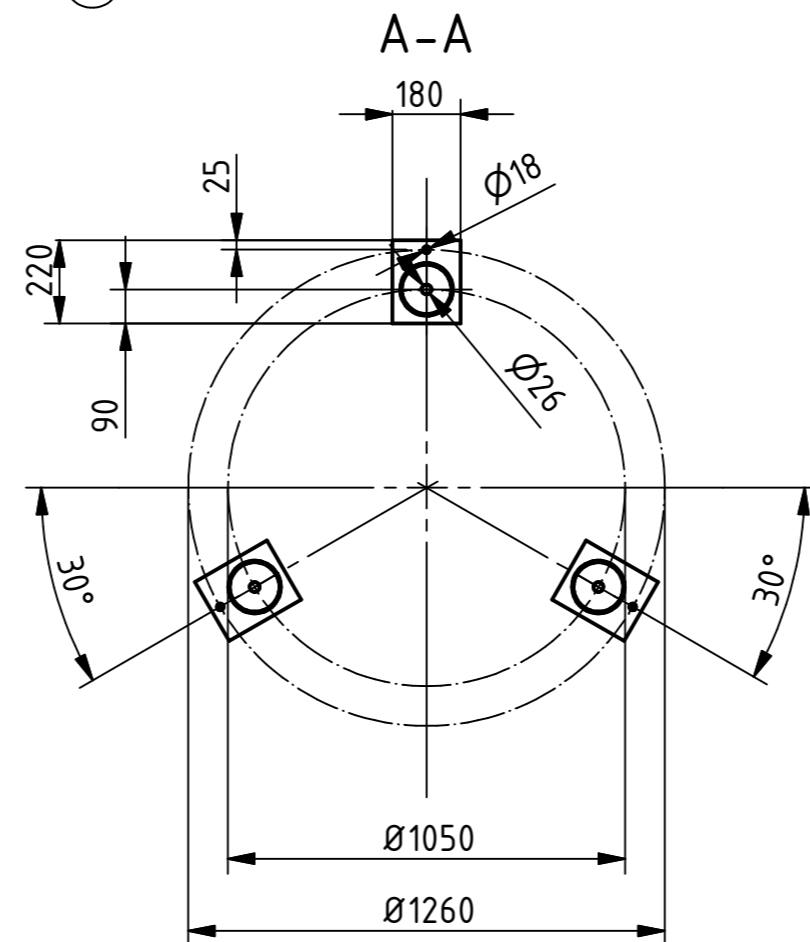

Commission	Pieces:		Scale: 1:20
	Date	Name	Weight: 1050 kg
Art.Nr.: 105251	Made by	Blum	Druckluftbehälter Compressed air receiver 5000 l 11 bar 105.528 1/2
	Checked by		
Atlas Copco			

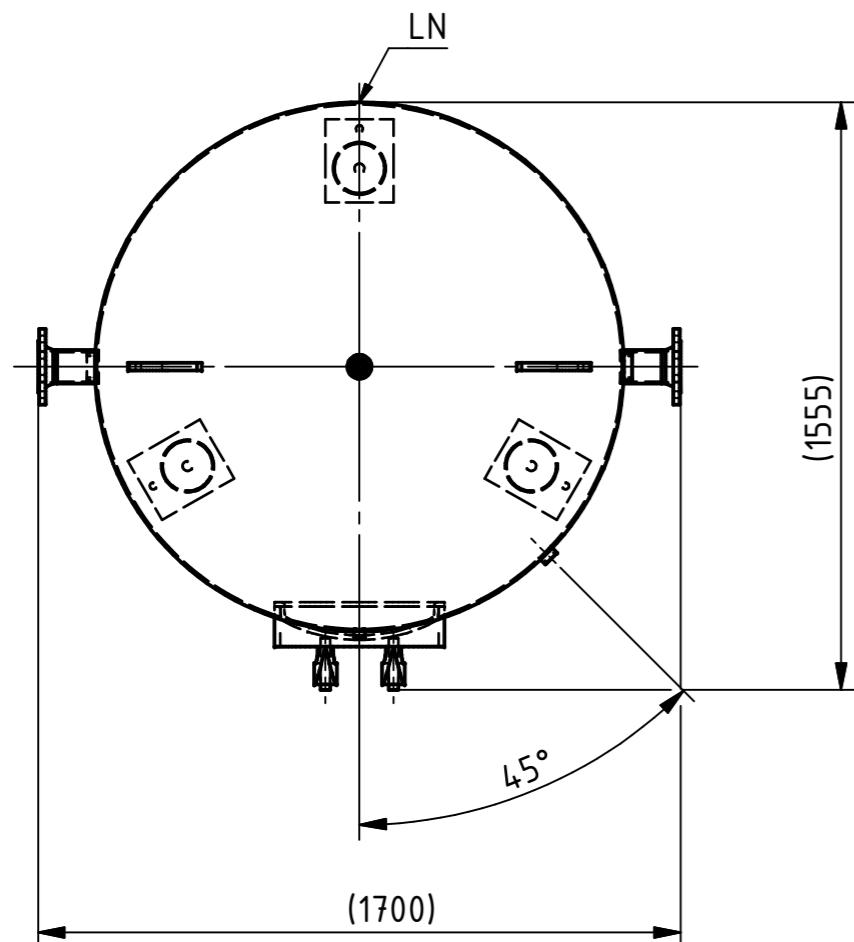
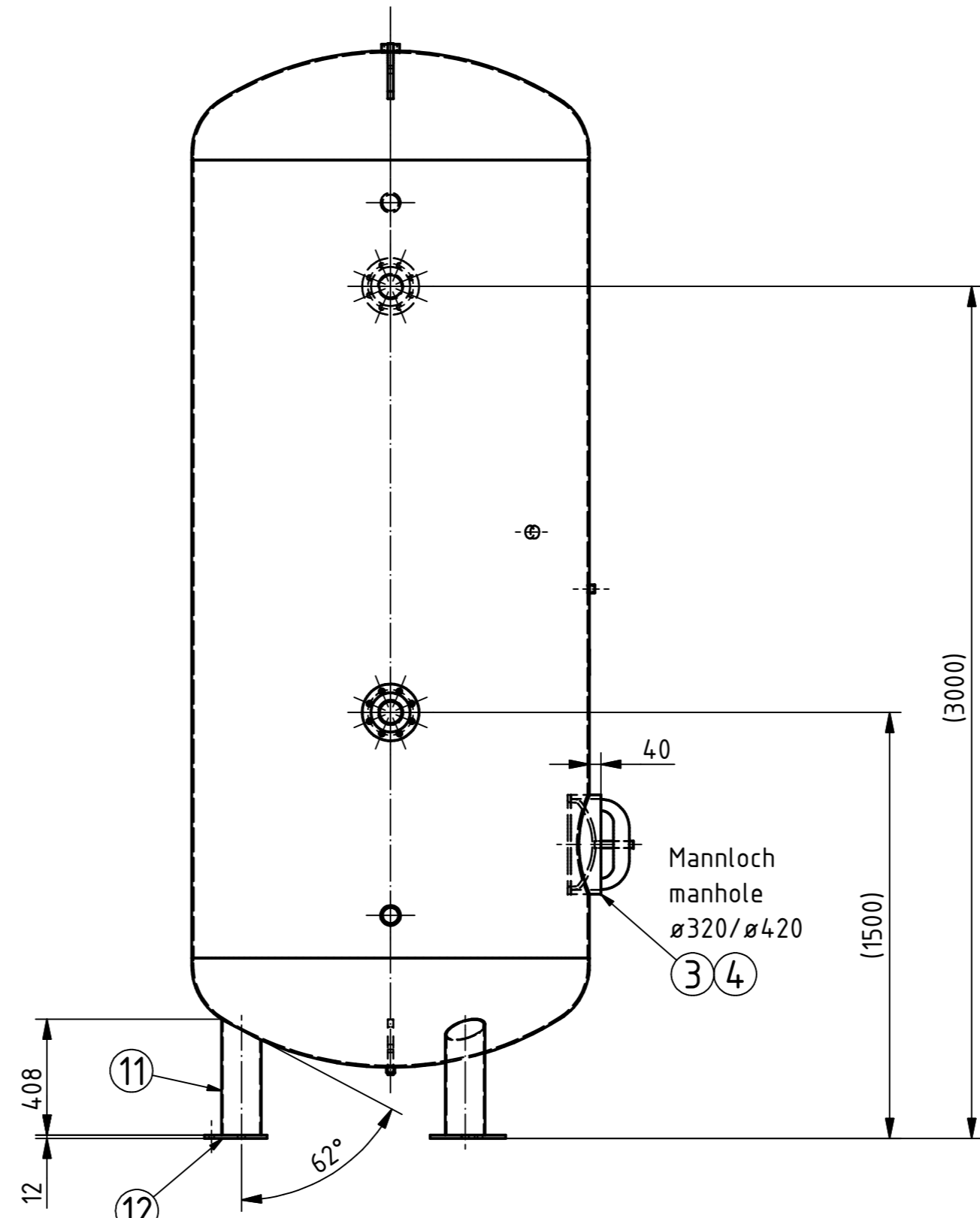
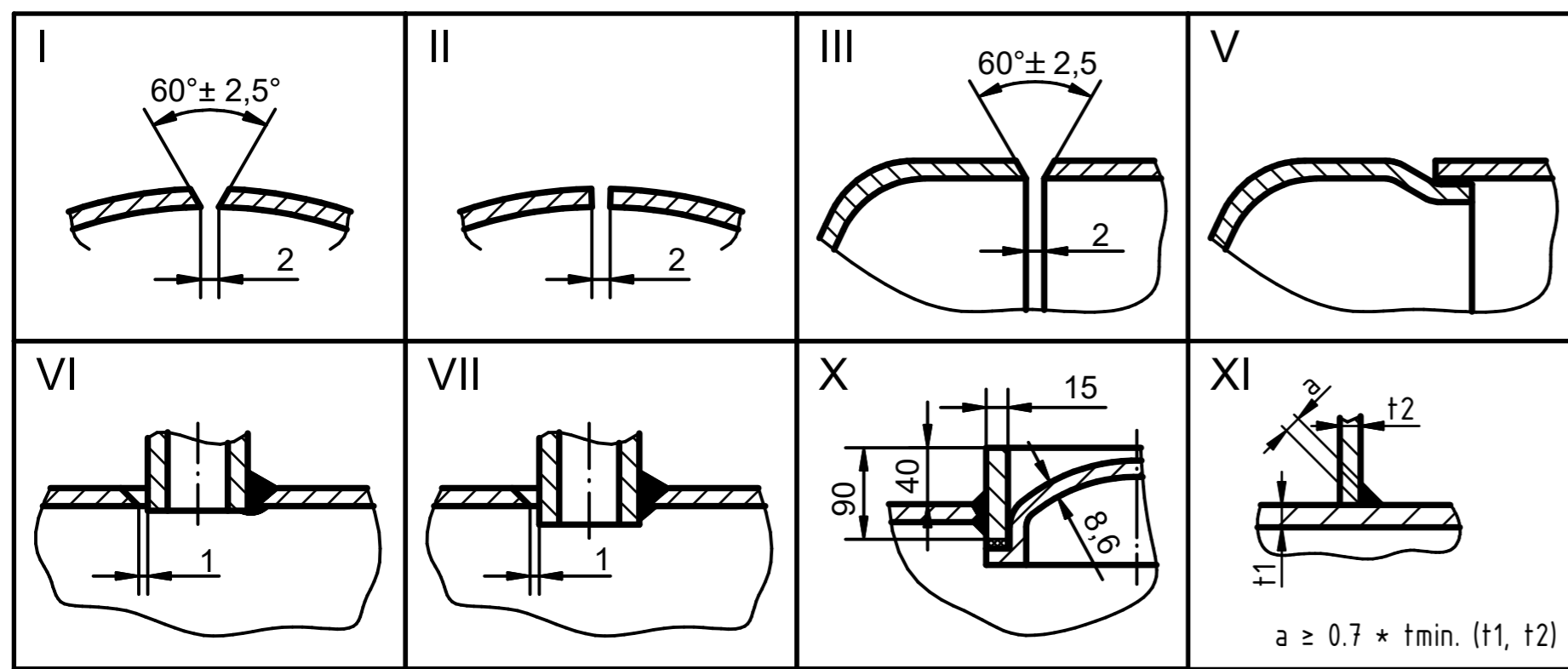

welding acc. to weld map 105.528

Pos.	Pcs.	Benennung / Description	Abmessungen / Dimensions	Norm / Standard	Cert.	Material
1	1	Mantelblech / shell plate	2810 x 4374 x 7,0	EN 10028-2 W1 EN 10204	3.1	P 265 GH
2	2	Korbbogenboden / head DIN 28013	ø1400 x 6,2 min.	EN 10028-2 W1 EN 10204	3.1	P 265 GH
3	1	Mannlochring / man hole ring	90 x 15	EN 10216-2 W4 EN 10204	3.1	P 265 GH
4	1	Mannlochdeckel / man hole cover	sD = 8,6	EN 10028-2 W1 EN 10204	3.1	P 265 GH
5	2	V-Flansch / welding neck flange	Typ 11/Form B1/DN 80/PN 16 EN 1092-1	EN 10222-2 W9 EN 10204	3.1	P 250 GH
6	2	Rohr / pipe	ø88,9 x 5,6 - 110 lg.	EN 10216-2 W4 EN 10204/ EN 10217-2 W4 EN 10204	3.1	P 235 GH
7	3	Muffe / inside threaded connection	G 2" - äø70 x 28 lg.	EN 10216-2 W4 EN 10204	3.1	P 235 GH
8	1	Muffe / inside threaded connection	G 1 1/2" - äø63,5 x 30 lg.	EN 10216-2 W4 EN 10204	3.1	P235GH
9	1	Muffe / inside threaded connection	G 1" - äø44,5 x 25 lg.	EN 10216-2 W4 EN 10204	3.1	P 235 GH
10	2	Muffe / inside threaded connection	G 1/2" - äø30 x 25 lg.	EN 10216-2 W4 EN 10204	3.1	P 235 GH
11	3	Fußrohr / support pipe	ø139,7 x 5,0 - 408 lg.	EN 10216-2 W4 EN 10204	3.1	P 235 GH
12	3	Fußplatte / foot plate	180 x 220 x 12	EN 10025 W1		S 235 JR
13	3	Kranöse / lifting eye 02-13	200 x 160 x 20	EN 10025 W1		S 235 JR
14	1	Typenschild / name plate	120 x 85			Folie / foil

operating pressure: 11 bar
test pressure: 15.73 bar
operating temperature: -10/50°C
capacity: 5000 l
medium: air
fluid group: 2
joint factor: 0.85
allowance for corrosion: 1.0 mm
design code: AD-2000, 2014/68/EU (PED), category IV, module B (production type)

drawing no. of prod. type: 105....
inspection by: manufacturer (module D)

Betriebsüberdruck: 11 bar
Prüfdruck: 15,73 bar
Betriebstemperatur: -10/50°C
Inhalt: 5000 l
Beschiekungsgut: Luft
Fluidgruppe: 2
Schweißfaktor: 0,85
Korrosionszuschlag: 1,0 mm
Berechnungsgrundlage: AD-2000, 2014/68/EU, Kategorie IV, Modul B (Baumuster)

Zeichnungsnr. d. Baumusters: 105....
Abnahme: Hersteller (Modul D)

Oberflächenbehandlung/surface treatment:
verzinkt / galvanized

Pieces:		Scale: 1:20	
Commission		Weight: 1050 kg	
Made by	Date	Name	Druckluftbehälter Compressed air receiver 5000 l 11 bar 105.528 2 / 2
30.06.2023	Blum		
Checked by			